

Walking Aids

In designing aids for a child, we need to think not only about her type and amount of disability, but also the stage of progress she is at. For learning to walk, she may progress through a series of stages and aids. Here is an example:

1. Parallel bars

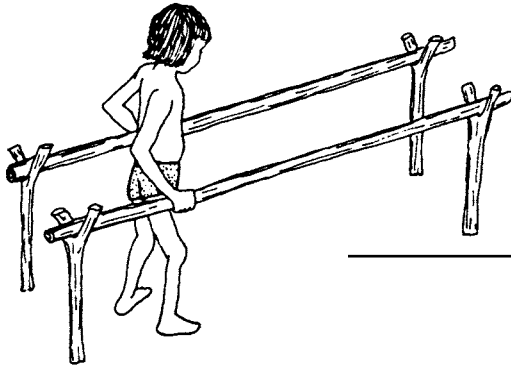

2. Wheeled walker

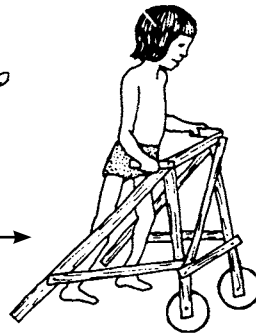

3. Crutches modified to form walker

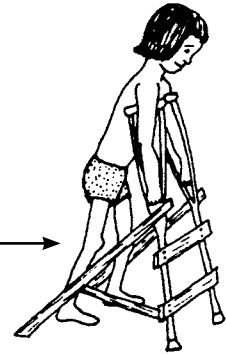

4. Underarm crutches



5. Below elbow crutches

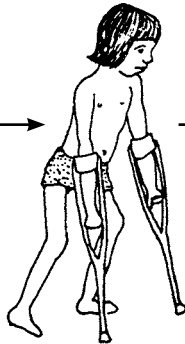

6. Cane with wide base

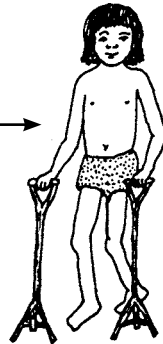

7. Walking stick (cane)



8. If possible, no aids at all

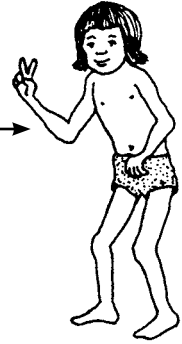

In this chapter we show a variety of aids for walking. Most can be made easily out of tree branches or wood. Some can be made from building construction bars (reinforcing rod) or metal tubing, and may require welding.

We include these ideas not to ask you to copy them, but with the hope that they will trigger your imagination. Take ideas from these designs, and use the materials you have at hand. When possible, make your aids to meet the needs of the individual child.

At a village rehabilitation center, it helps to have a wide selection of aids on hand, so that you can try different ones on a particular child to find out what works and what she likes best.

Parallel bars

Simple designs for outdoor parallel bars, both adjustable and non-adjustable, are included in Chapter 46 on playgrounds, pp. 417 and 425. On p. 417 we also give suggestions for adjusting the bar height to meet the needs of the individual child. The designs shown are:

OUTDOOR BARS

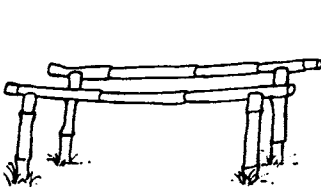

simple, non-adjustable bars
(bamboo, wood, or metal)

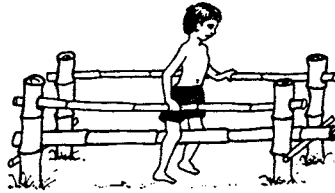

bars with a leg separator for a child whose knees pull together

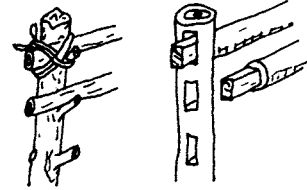

2 designs for bars with adjustable height

INDOOR BARS (design details for two of several models)

ADJUSTABLE MODEL

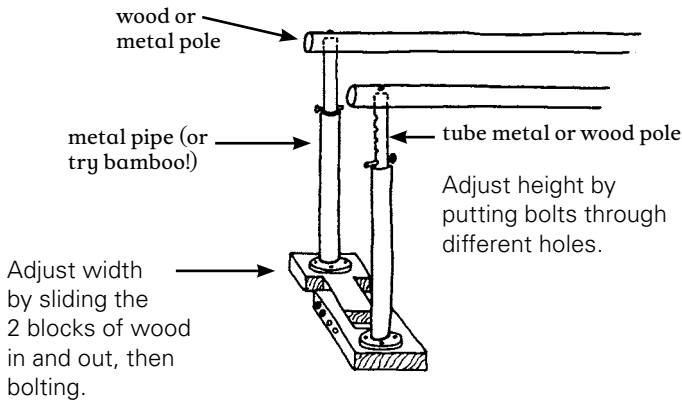

NON-ADJUSTABLE MODEL

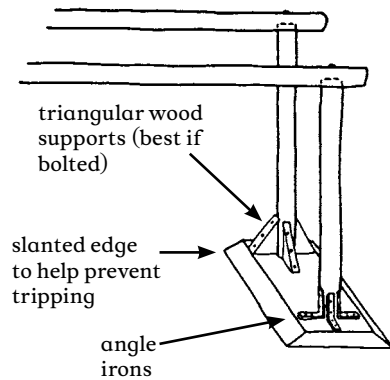

IRON PIPE BARS

Design from *Functional Aids for the Multiply Handicapped*

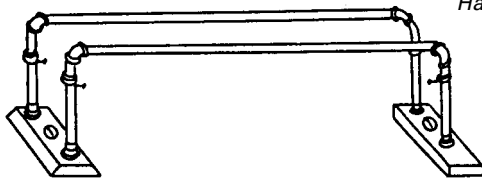

NON-ADJUSTABLE BARS

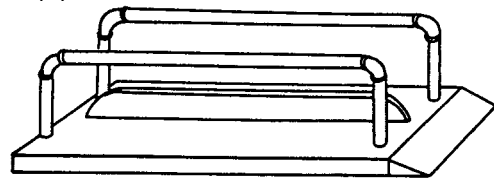

WITH FOOT DIVIDER

METAL CONDUIT TUBING

ADJUSTABLE WIDTH BARS

Designs from *Poliomyelitis, Huckstep*.

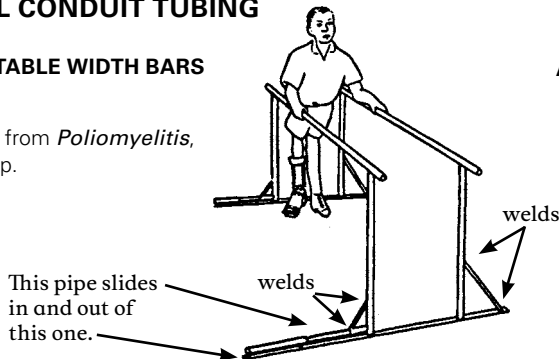

ADJUSTABLE WIDTH AND HEIGHT

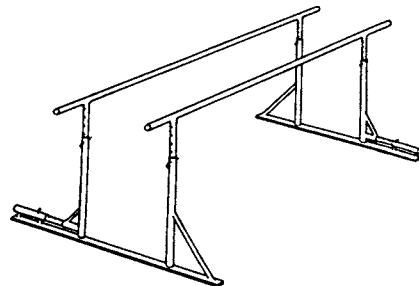

Walkers

There are many ways to make walkers or walking frames. Here we show a range from very simple to more complex. Choose the design and height depending on the child's needs and size.

Julio has strong arms and good body control. He can use a simple low walker.

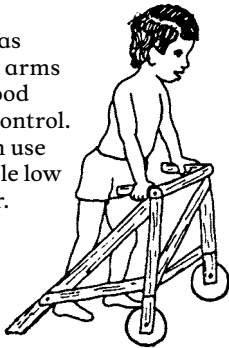

Lico has weak elbows and poor balance or body control. He needs a higher walker with armrests.

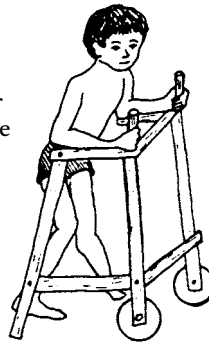

Anna has weak legs and poor balance. She does best with underarm crutches built into the walker.

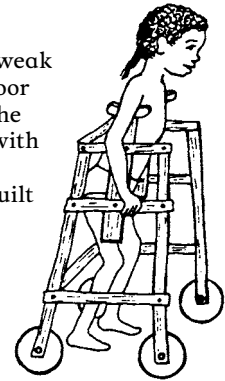

The above walkers can be made with 2 cm. x 4 cm. boards (such as those used on roofs to hold tiles), or thin trees or branches. The wood or plywood wheels roll easily when little weight is on them (when child pushes walker) but have a braking action when child puts full weight on them (when taking a step).



SIDE VIEW

Round edges of handle.

Triangular construction adds strength.

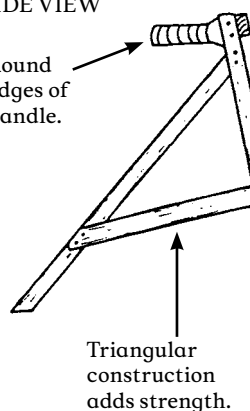

FRONT VIEW

Diagonal support adds strength.

nails

wood or plywood wheel

piece of steel construction rod (re-bar)

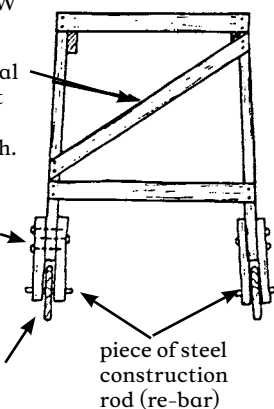

Finding the design that works best for a particular child often involves experimenting and changing different features.

For example. Carlota has poor body and hip control, and tends to fall through the space between her arms when the handgrips are upright.



A higher walker with a bar as the handgrip works better for her.

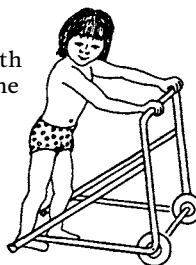

This walker with slanting bars lets a child hold it at the height that he finds works best.

These walkers can be made out of welded or bolted metal tubing.

Other walker designs

WALKER MADE FROM CANE, RATTAN, OR BAMBOO

Design from *Rattan and Bamboo Equipment For Handicapped Children*, J. K. Hutt.

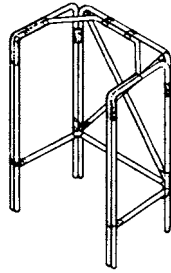

Joints can be tied with cane, ribbon, nylon string, strips of car inner tube or whatever.

WOOD WALKER

Design by Don Caston.



Wood walker for a child whose legs need to be held apart.

Note: A walker with no wheels is very stable but harder to move.



A walker with 2 wheels and 2 posts is fairly stable but easy to move.



A walker with 3 or 4 wheels is very easy to move but can easily roll out from under the child (unless the child is seated).

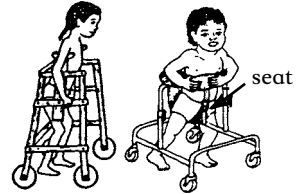

WALKER MADE FROM SOLID IRON ROD (RE-BAR) WITH ARMRESTS—WELDING REQUIRED

Design from *Simple Prosthesis Manufacture*, Chris Dartnell.

Measure child.

Cut and bend rod.

Assemble walker.

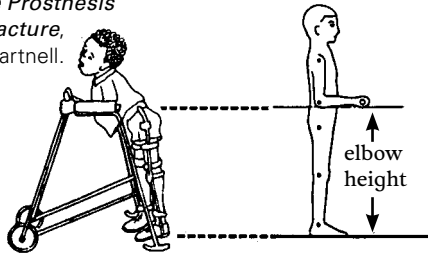

SIDE VIEW

FRONT VIEW

ARMREST

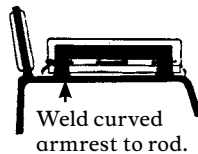
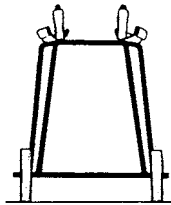
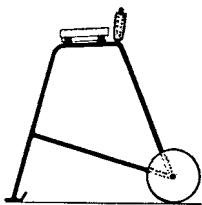

Weld curved armrest to rod.

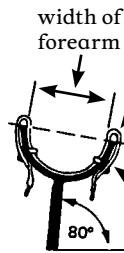

width of forearm

angled toward body
leather, cardboard, plastic, or sponge

wheel

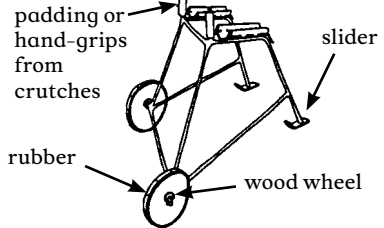
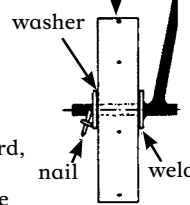

SIMPLE WALKER MADE FROM SOLID IRON ROD (RE-BAR)—WELDING REQUIRED

Design from *Simple Prosthesis Manufacture*, Chris Dartnell.

Cut and weld rod.

SIDE VIEW

FRONT VIEW

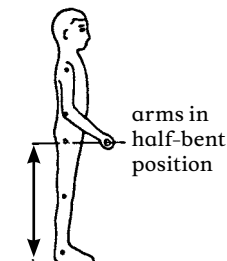
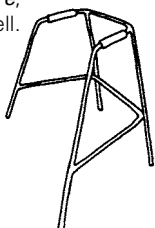

arms in half-bent position

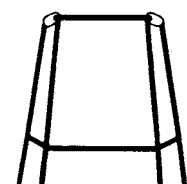
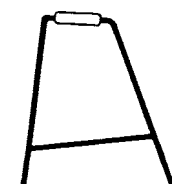
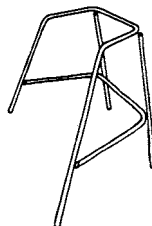

CART WALKERS

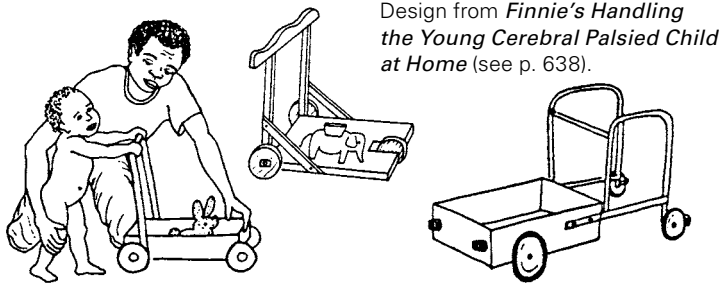

Design from *Finnie's Handling the Young Cerebral Palsied Child at Home* (see p. 638).

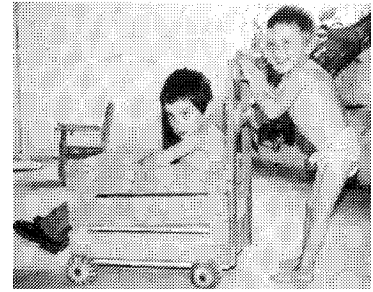

CP

The added weight in the cart can help the child stand firmly—and makes learning to walk more fun.

As the child progresses, he can change his grip from the front bar to the side bars.

Wheels on this cart walker are made from the round seed pods of a tree in Mexico, called Hava de San Ignacio.

ROLLER SEAT AND TRICYCLE WALKERS



Useful for a child with cerebral palsy who "bunny hops" (crawls pulling both legs forward together). Seat holds legs apart. The chimney helps child keep his arms up and apart.



Stable for the beginner



CP

Design from *Finnie's Handling the Young Cerebral Palsied Child at Home* (see p. 638).

WALKERS FOR SITTING AND STANDING

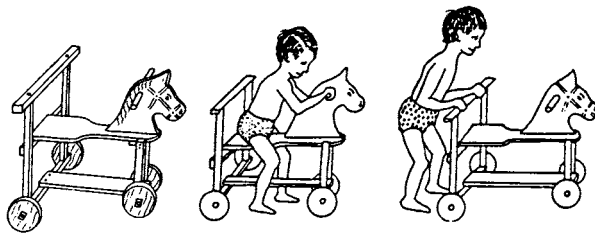

SPIDER WALKER

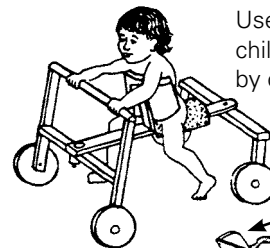

Useful for the small child severely affected by cerebral palsy.

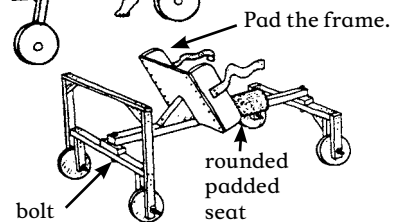

CP

SADDLE-TYPE WALKER

Design from *UPKARAN Manual*

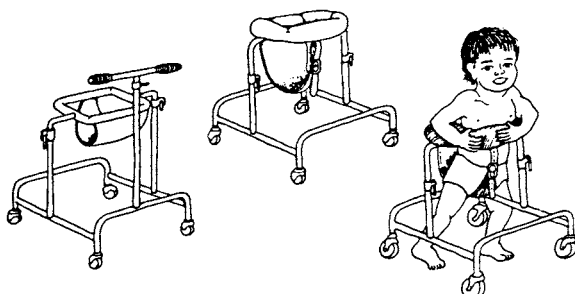

CAUTION: Sitting walkers should usually be used, if at all, as an early and temporary step toward walking. With them, the child does not learn to balance well and the hips are often at an angle which can form contractures (see Chapter 8, p. 86).

Crutches

MEASUREMENTS FOR UNDERARM CRUTCH

Top of crutch should be 3 fingers' width below armpit, so it does not press under the arms.

Elbow should be bent a little so that arms can lift body when walking.

Handgrip should be placed for comfort—usually about 1/3 of the way down crutch.

RIGHT



WRONG



WARNING: Bearing weight under the arms like this can cause nerve damage that in time can lead to numbness and even paralysis of the hands.

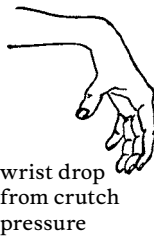

wrist drop from crutch pressure

RIGHT

Teach the child to put weight on her hands, not on her armpits.



full weight on hands

One good way to make sure the child does not hang on the crutches with her armpits is to use elbow crutches like this.

There are many designs for underarm crutches. Here we show a few.

CRUTCHES FROM TREE BRANCHES, padded with wild kapok

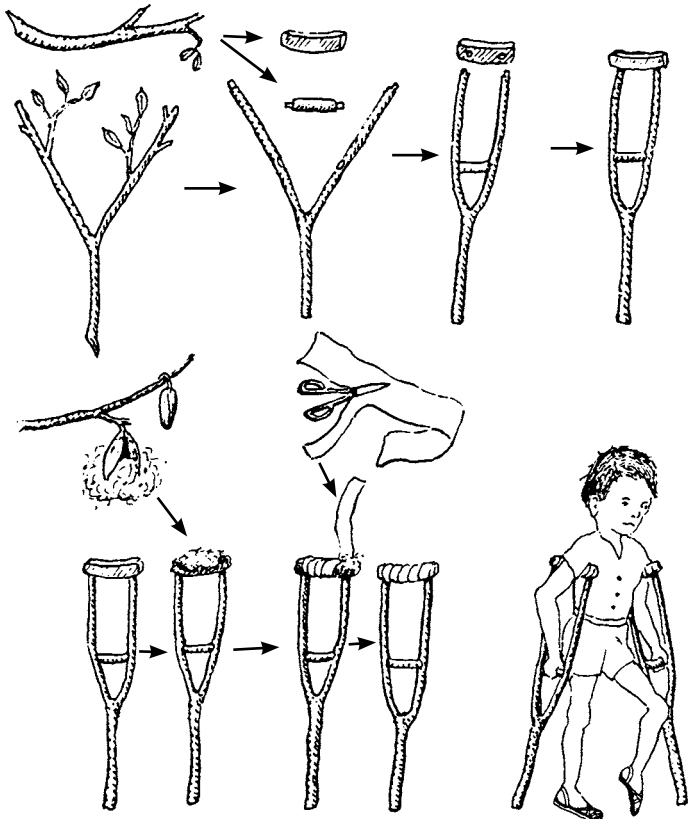

These single support designs using tree branches are not as strong as the double support design shown at left.

WOODEN CRUTCHES

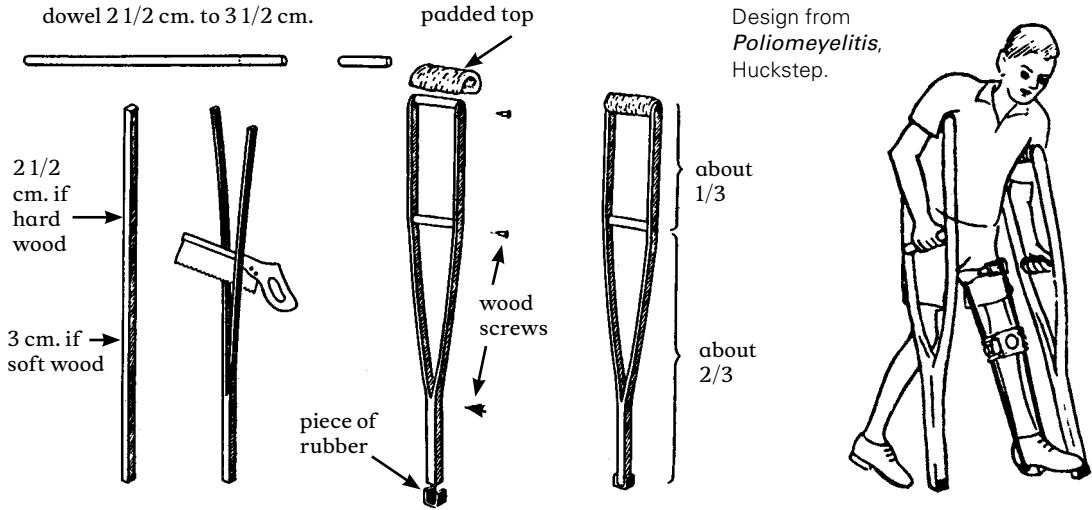

METAL CRUTCH

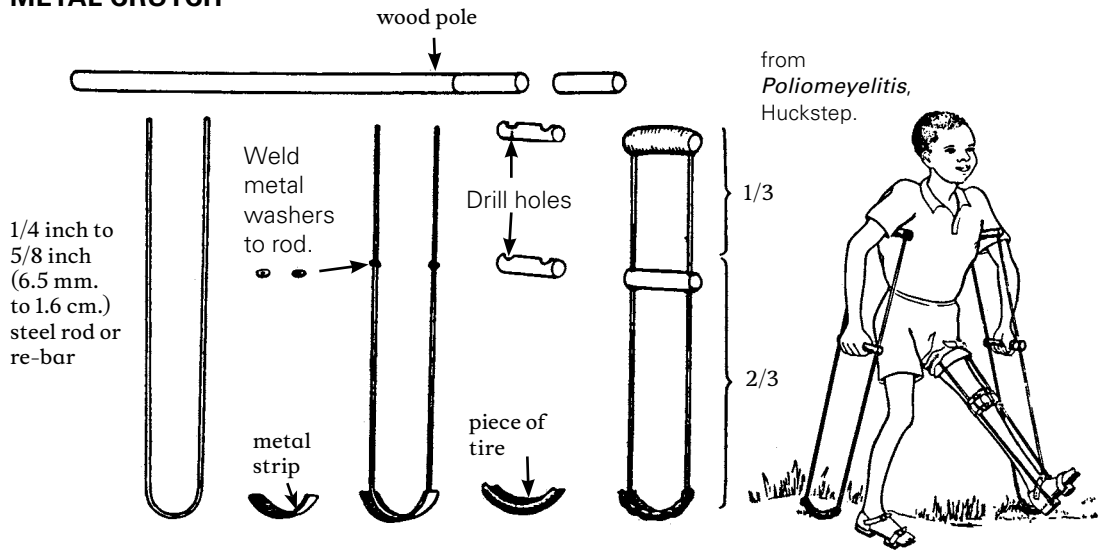

ADJUSTABLE WOOD CRUTCH

STANDARD

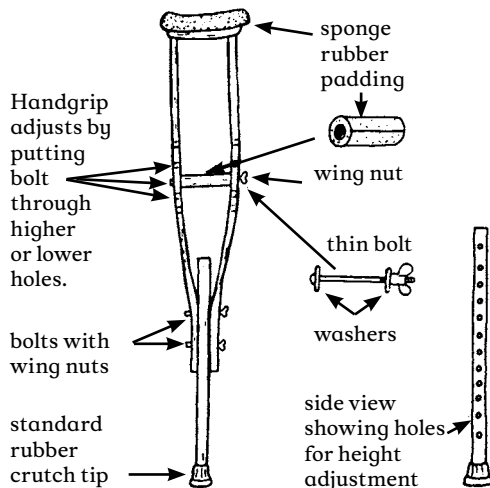

LEATHER RING ELBOW CRUTCH

These crutches are easy to make and work well for children who have strong arms and hands.

A disadvantage is that if a child falls he may have trouble getting his arms out quickly.

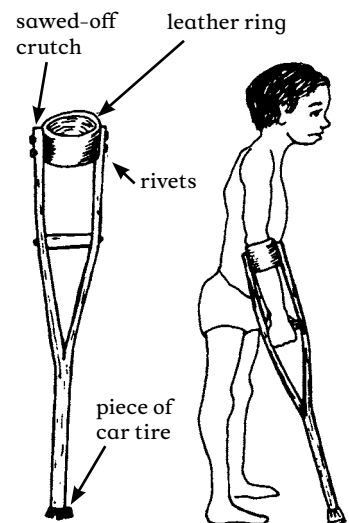

OTHER ELBOW CRUTCHES

With these open elbow-ring crutches, the child can easily get his arms out if he falls.

STANDARD ADJUSTABLE

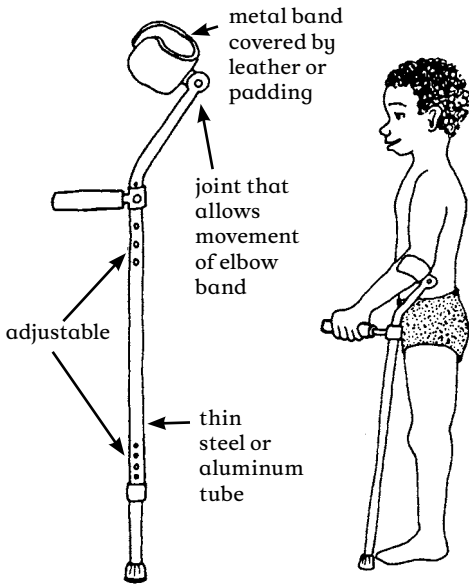

USING LOCAL RESOURCES

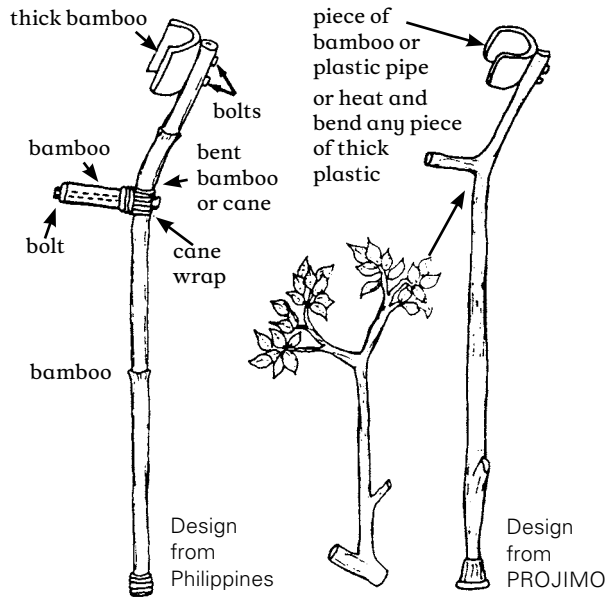

Gutter crutch ("arthritis crutch") for children who, due to elbow pain or stiffness, cannot use straight-arm crutches.

Crutch for a child with weak elbow-straightening muscles.

STANDARD

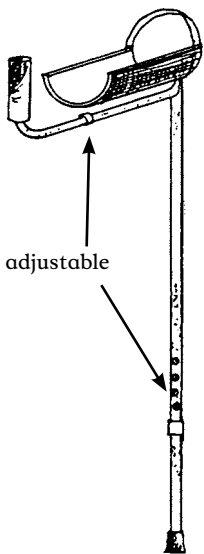

USING LOCAL RESOURCES

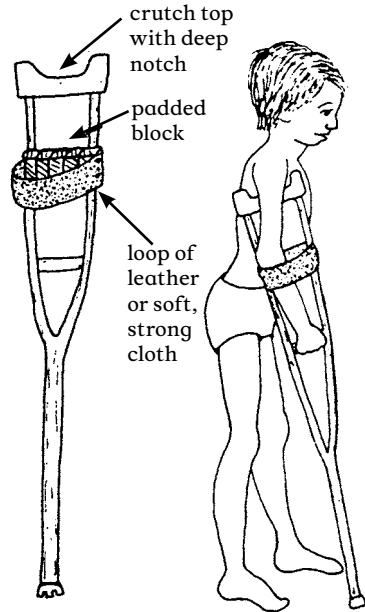
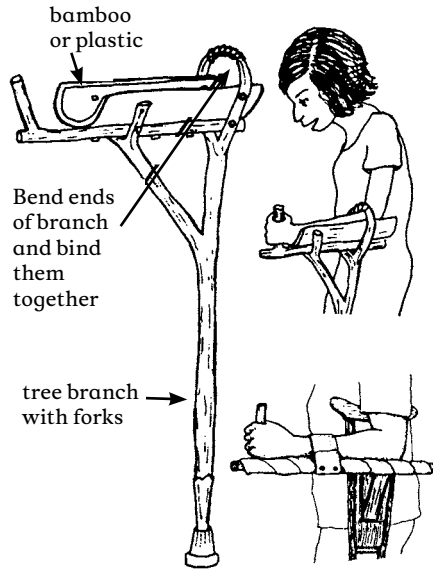

These are only examples. Once you get the idea, you can invent your own. A lot of experimentation is often needed to adapt crutches for children with severe arthritis.

Canes and walking sticks

Straight poles can help a child who has difficulty with balance.

CAUTION: Use poles that are taller than child so if she falls, they will not poke her eyes.

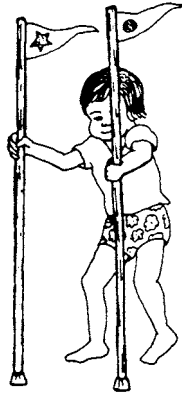

Canes. Simple canes provide some balance and support, but the child has to use the walking muscles in both legs.

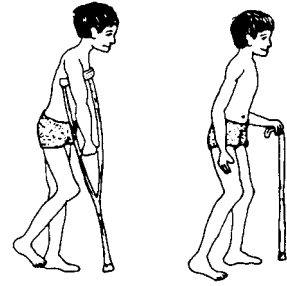

For the child who needs to strengthen a weak or painful leg, a cane makes him use his leg. A crutch lets him avoid using his leg, so the muscles that bend his leg get stronger, rather than the ones that straighten it (see p. 526).

CANES CUT FROM FOREST PLANTS

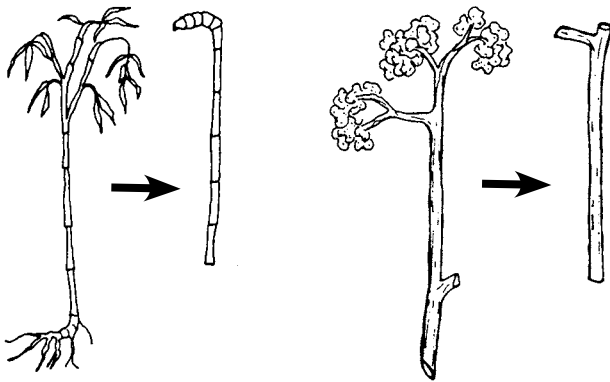

ADJUSTABLE METAL TUBE CANE

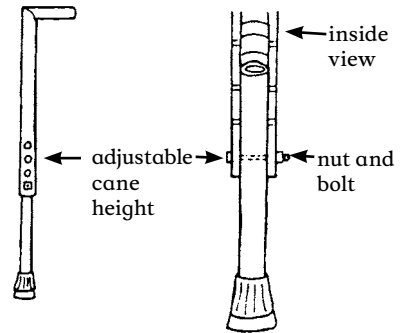

3 OR 4 FOOTED CANE—FOR GREATER STABILITY

STANDARD METAL TUBE

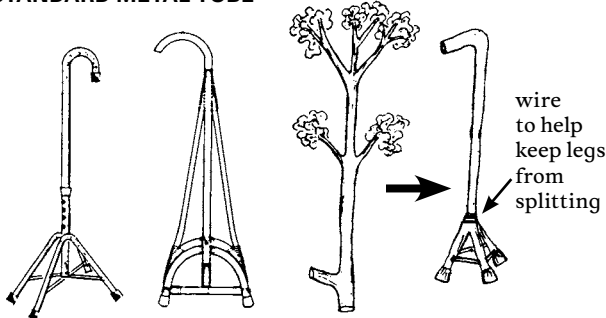

ALTERNATIVE HAND GRIP

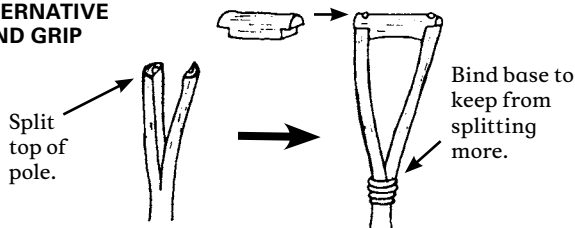

Rubber tip made from car tire for metal tube or bamboo crutch or cane

STANDARD CRUTCH AND CANE TIP

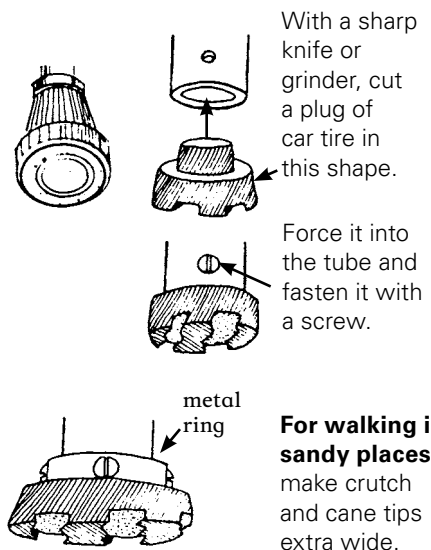

Adaptations of walking aids for carrying things and for work

CRUTCH SLING

to free hands
for work

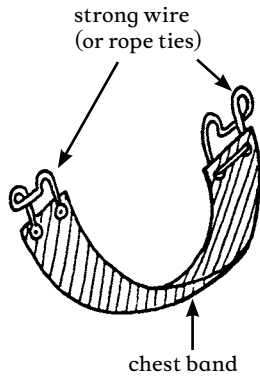

LEATHER OR CLOTH POUCH

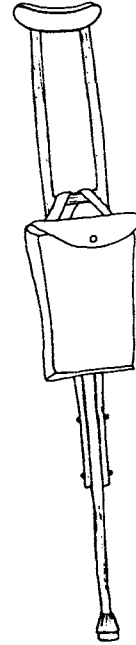

BACKPACK

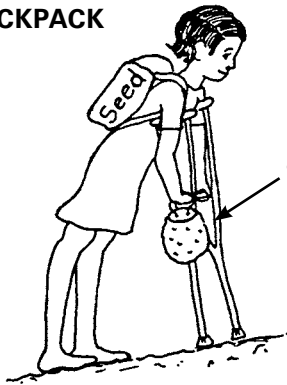

gourd

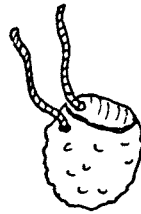

strong wire that hooks over crutch

HOE ADAPTED AS CRUTCH

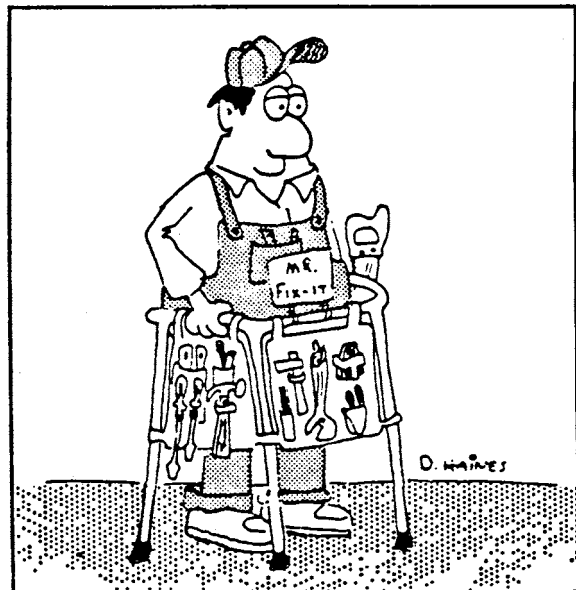
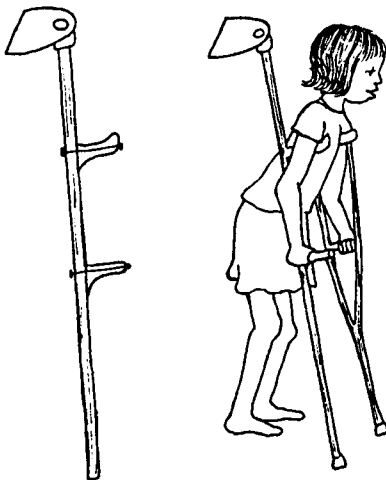

Reprinted from *Accent on Living*, 1984