

Developmental Aids

In this chapter we look at the design details of aids for lying, sitting, standing, balance, use of hands, and communication. Aids for walking are in Chapter 63.

Whether or not a particular child needs an aid, and what kind of aid she needs, must always be carefully and repeatedly evaluated. An aid that helps a child at one level of development may actually hold her back at another. When considering aids, we suggest you first read the chapters on child development, those covering the particular disability of the child, and Chapter 56.

NOTE: Many developmental aids have already been shown in PART 1 of this book, especially in Chapter 9 (cerebral palsy), and in Section C, on child development. Aids and equipment for play and exercise are in PART 2, Chapter 46 (Playgrounds). Wheelboards and wheelchairs are in Chapters 64, 65, and 66.

Lying aids

Lying face down is a good position for a child to begin to develop control of the head, shoulders, arms, and hands, and also to stretch muscles in the hips, knees, and shoulders. However, some children have difficulty in this position. For example:

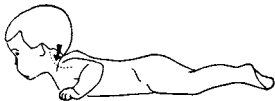

Rosa cannot lift her shoulders. She has to bend her neck far back to lift her head.



Juan does not have enough control and balance to reach out his arms.



A firm pillow under the chest may help both these children to lift their heads better and to reach out.

CP

A wedge or slanting support is often helpful. The height depends on the needs of the particular child.

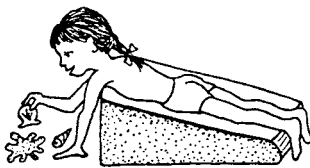

Diana manages best on a wedge high enough so that she can lift herself up a little at arm's length. (Height is the length from wrist to armpit.)

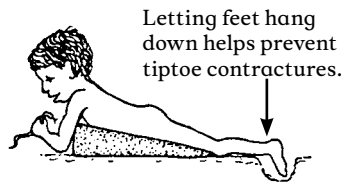

Cassio does better on a lower wedge, so he can lift up on his elbows. (Height is slightly less than length from elbow to armpit.)

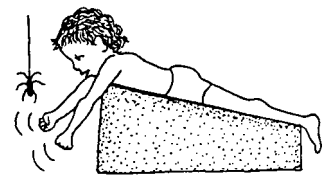

Carmen and others with little or no arm or hand control do best when their arms can dangle. She can see them moving when she moves her shoulders.

Wedges can be made with:

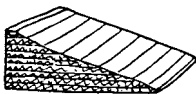

stiff foam plastic or layers of cardboard

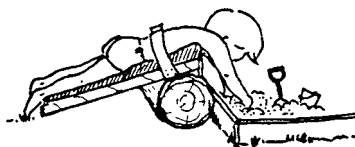

a log and a board with a soft foam cover

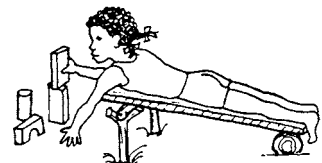

a stick frame

If necessary, a leg separator can be added (see p. 81).

Or sides can be included for the child who needs to be *positioned* with supports or cushions.

CP

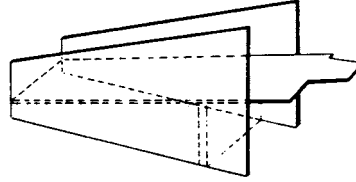
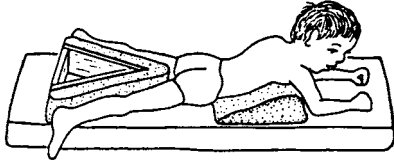

Design from *Functional Aids for the Multiply Handicapped*.

Some children are able to control their shoulders, arms, and hands better when lying on one side.

CP

A side-lying frame may be helpful for some children with severe cerebral palsy. Try cushions or padded blocks of different shapes until you find what works best. Use straps only if clearly needed to keep a good position.

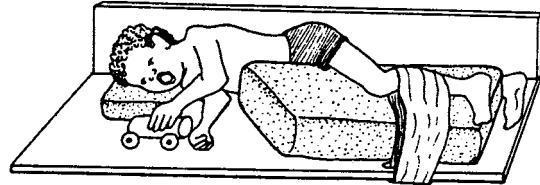

Also see lying frames for straightening hip flexion contractures (pp. 81 and 86), and lying frames with wheels (pp. 618 and 619).

ADJUSTABLE BEDS

This design from the Centre for the Rehabilitation of the Paralysed in Bangladesh adjusts easily from an upper position to a lower position.

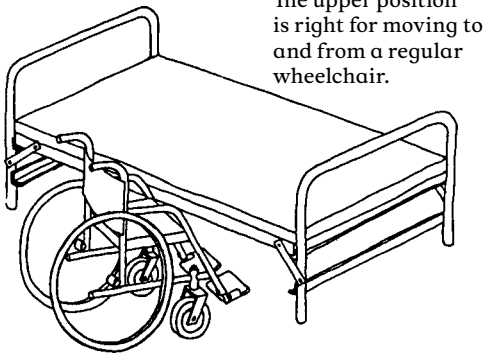

The upper position is right for moving to and from a regular wheelchair.

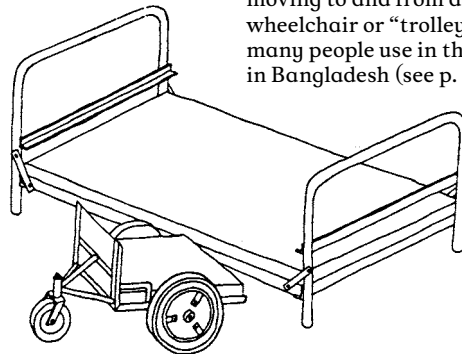

The lower position is right for moving to and from a low-level wheelchair or “trolley,” which many people use in their houses in Bangladesh (see p. 590).

These metal beds and wheelchairs are welded together by workers with paraplegia. For the coconut fiber mattresses they use, see p. 199.

Adjustable back support clamp

Supporting a person with paralysis so he lies on his side can be difficult. Pillows easily move or slip. This simple clamp helps solve the problem. It was designed and made by workers with disabilities at the Centre for the Rehabilitation of the Paralysed, Dhaka, Bangladesh (see p. 518).

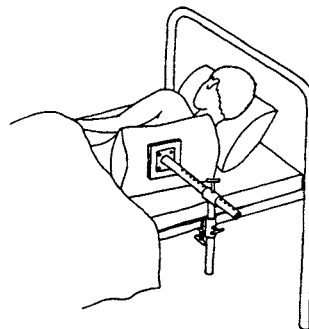

CAUTION: To prevent pressure sores, be sure the child changes position often (see Chapter 24).

Sitting Aids



A wide variety of early sitting aids are included in the chapter on cerebral palsy (see pp. 97 and 98). Special seating adaptations for chairs and wheelchairs are in Chapter 65.

Here we include a few more ideas:

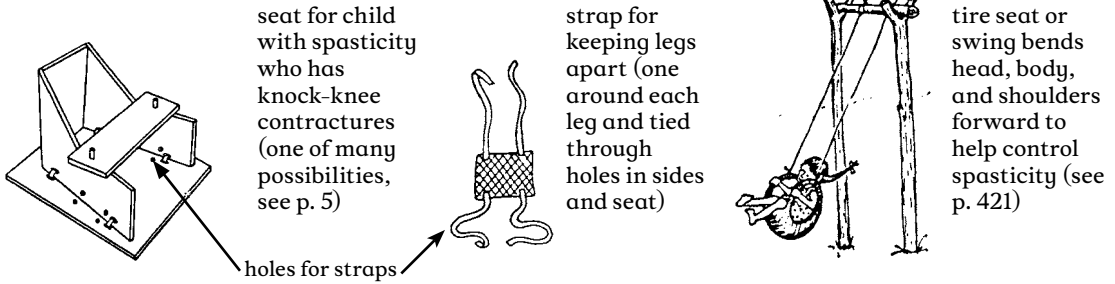

seat for child with spasticity who has knock-knee contractures (one of many possibilities, see p. 5)

strap for keeping legs apart (one around each leg and tied through holes in sides and seat)

tire seat or swing bends head, body, and shoulders forward to help control spasticity (see p. 421)

A log or roll seat helps the child who has spasticity or difficulty with balance sit more securely with legs apart. Log should be as high as the knees. Leave a little space between the table cut-out and the child's belly.

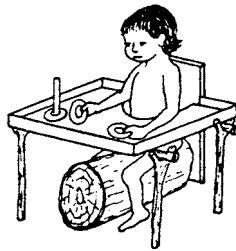

seat for a child with spasticity whose body stiffens backward

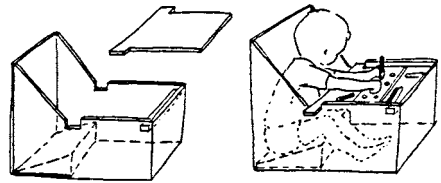

Design from *Handling the Young Cerebral Palsied Child at Home* (see p. 638).

OTHER IDEAS FOR HOLDING LEGS APART

From Don Caston and Healthlink Worldwide:

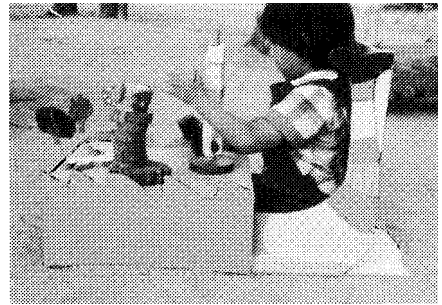
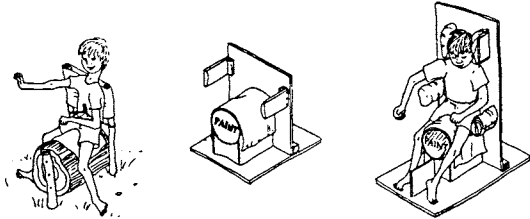

A seat and table like this in the form of a fish on the ocean makes sitting in a special seat fun. So do the village-made toys (PROJIMO, seat design by Don Caston).

from other parts of this book:

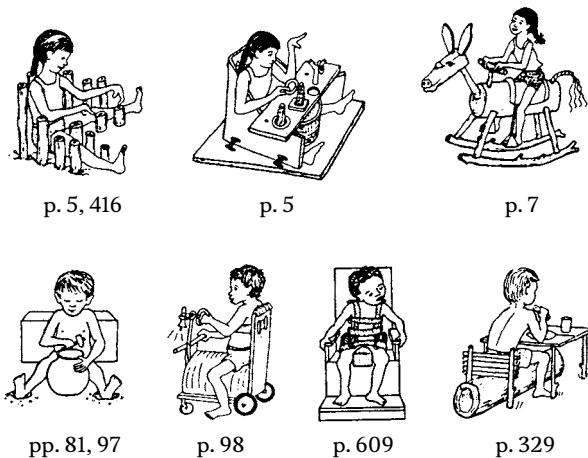

The seat can be used for straight leg sitting, or put on top of the table for bent-knee sitting. Other designs include "squirrel" seats on "tree" tables.

For more ideas on adapted seating, see Chapters 9, 35, and 65. Also, see scooters and walkers with roll seats, p. 98.

Standing aids (see also pp. 99, 312, and 500)

CP Many children who have difficulty with balance or control when standing may benefit from standing or playing in a "standing aid." Even for the child who may never stand or walk on her own, being held in a standing position with weight on her legs helps circulation and bone growth and strength.

STANDING BOARD

Sometimes a child who does not have enough control or strength to hold his head when lying,

can hold his head up better when sitting or standing.

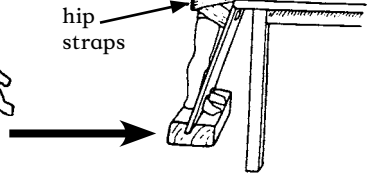
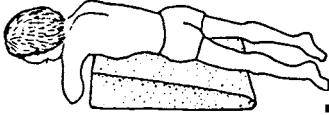

A simple standing board can help hold the child in a stable position. This one leans against a table.

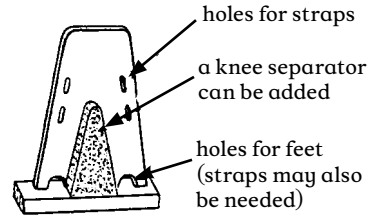

LEANING BOARD

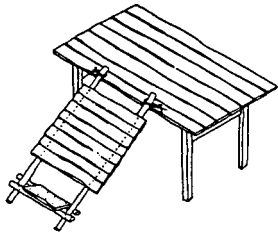

from Don Caston and HealthLink (see p. 604)

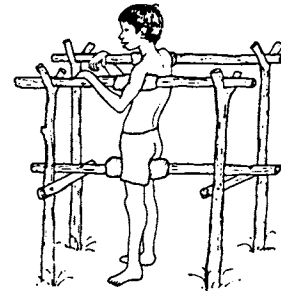
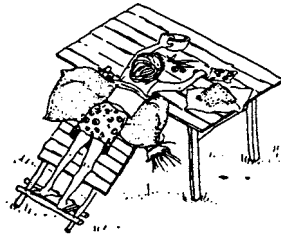

BACK-BOARD

This can be used to gradually bring a child to a standing position. It is especially useful for older children who get dizzy if brought to a standing position too quickly. This can happen after a spinal cord injury or a long, severe illness. The child can be stood up gradually and for longer each day.

Use angle irons to hold boards firmly.

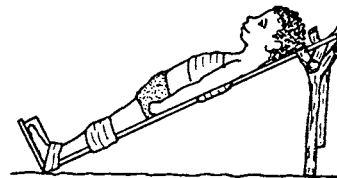
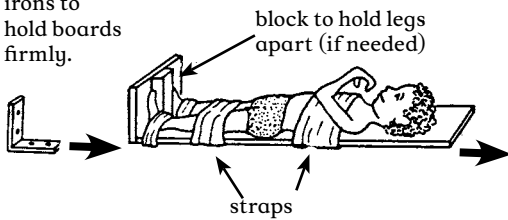

STAND-IN TABLE

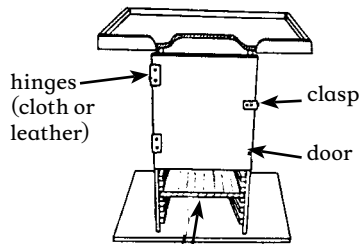
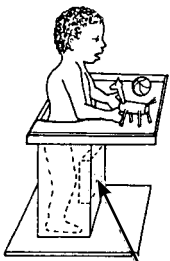

padded knee block

OTHER IDEAS



large tile or cement pipe

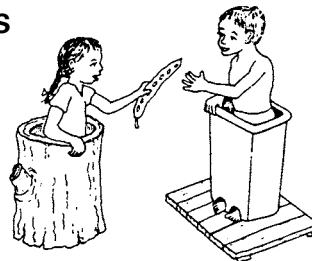

hollow log (like people use for bee hives)

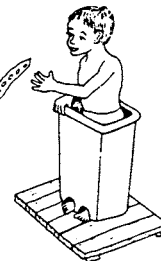

plastic garbage container. (Fasten it to a wide base to keep it from tipping over.)

STANDING FRAMES

These are mainly for a child with contractures or painful joints who has difficulty standing straight. The child can gradually be straightened up.

ADJUSTABLE MODEL

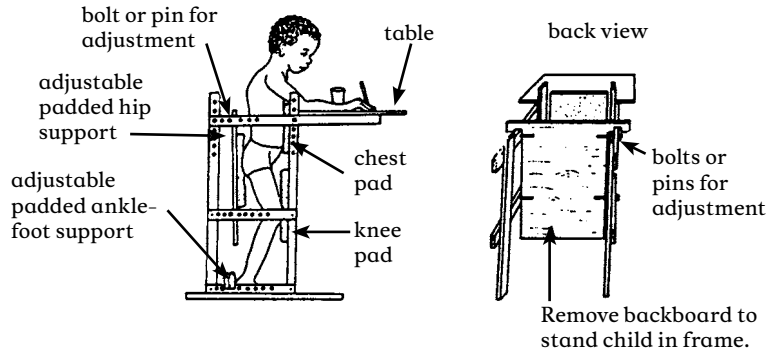

MOVABLE MODEL

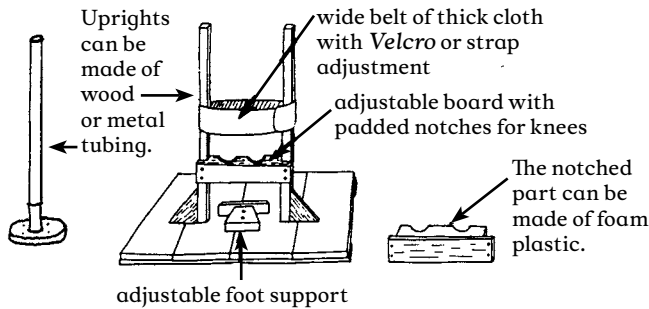

SIMPLE FIXED MODEL

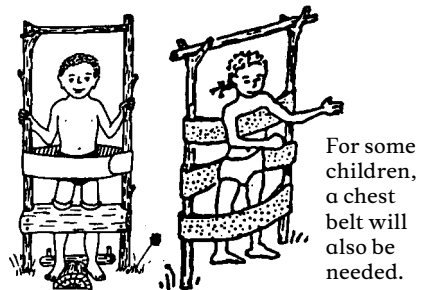

STANDING-AND-WALKING FRAME

This is a useful aid to begin standing and walking, for children paralyzed or severely affected below the waist (paraplegia, spina bifida, diplegic cerebral palsy).

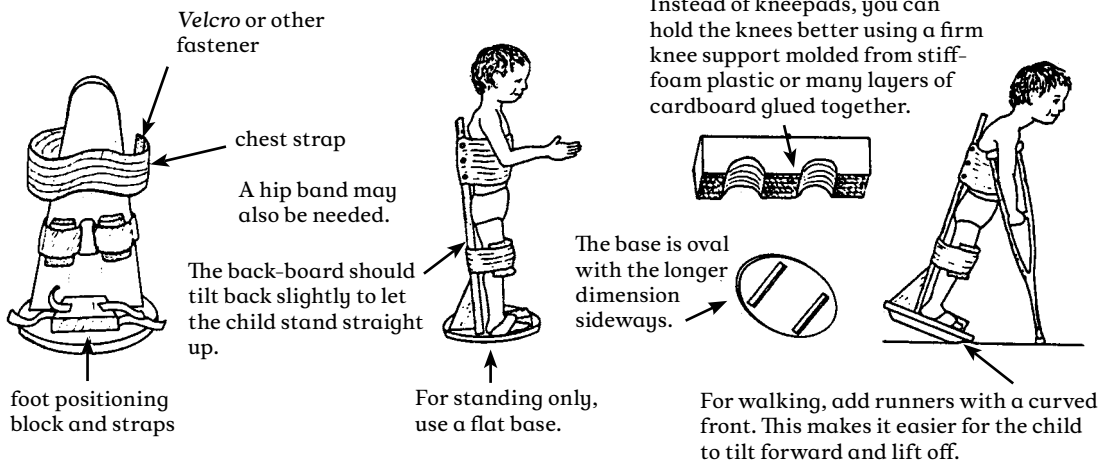

STANDING-WALKING BRACE

This has the same use as the standing-walking frame above, but is especially useful for children who need to learn how to walk before they are fitted for braces with a hip band or body brace.

DESIGN THAT DOES NOT ALLOW SITTING

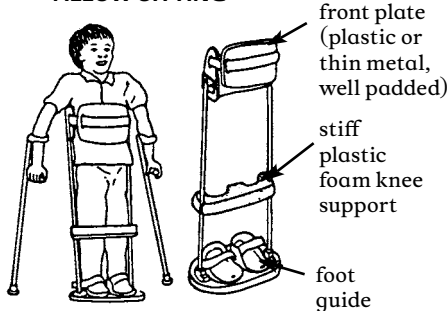

DESIGN WITH HIP AND KNEE HINGES TO ALLOW SITTING

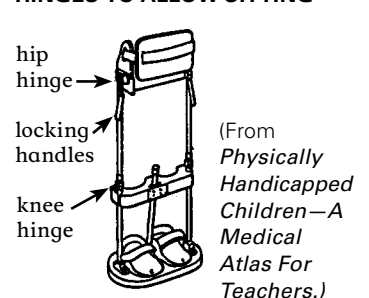

CP Aids for balancing and body control

Activities for improving balance are discussed on pp. 105, 311, and 312. Here we bring together a few of the aids for balancing that are shown in different parts of this book, together with a few new ones.

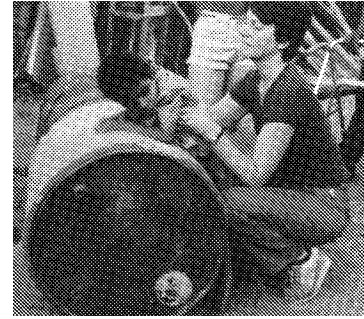

An old drum or barrel makes a good "roll" for exercise and positioning.

BALANCE BOARDS

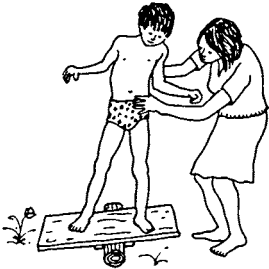

A balance board like this rocks less smoothly because the center rocker is so narrow.



A wider rocker works better.



An upright stick can be used at first to help her keep her balance.

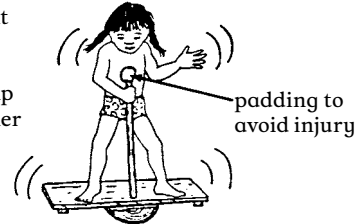

BALANCE BEAMS

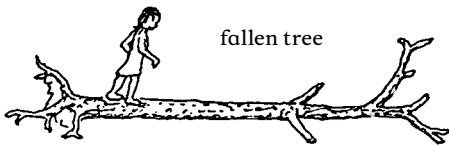

fallen tree

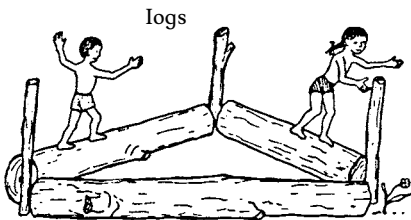

logs

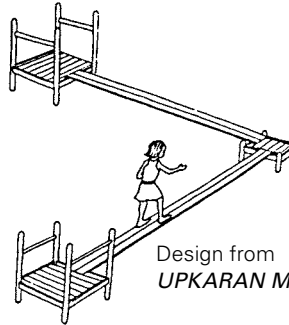

Design from UPKARAN Manual

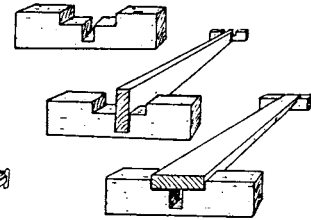

adjustable wide or narrow balance beam



For the child whose ankles bend in,

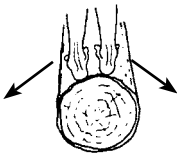

walking on a log helps bend the ankles outward.

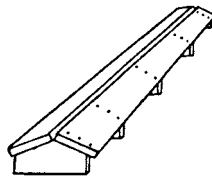

Or the child can walk on slanting boards, like this.



For the child whose ankles bend outward,



walking on boards like this helps bend the ankles inward.

To improve balance also see swings, rocking horses and merry-go-rounds.

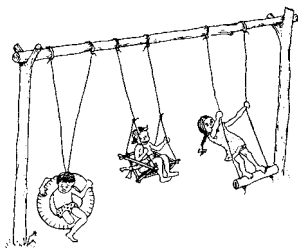

pp. 420 and 421

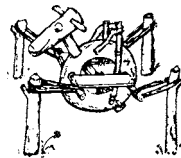

p. 422



p. 425

Other aids

Many aids not yet described in PART 3 have been described in other parts of this book. Here is a brief summary of some of these to give you basic ideas and tell you where to look. We also give a few ideas of aids not shown before.

EATING AND DRINKING AIDS

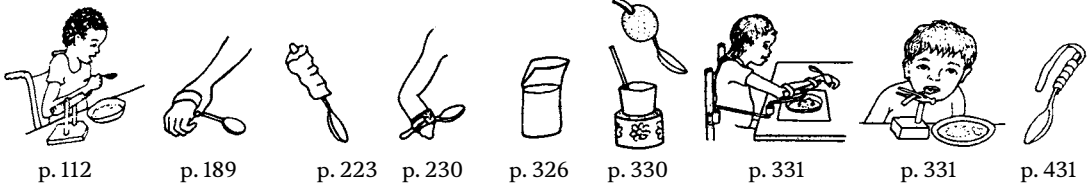

TOILETING AIDS

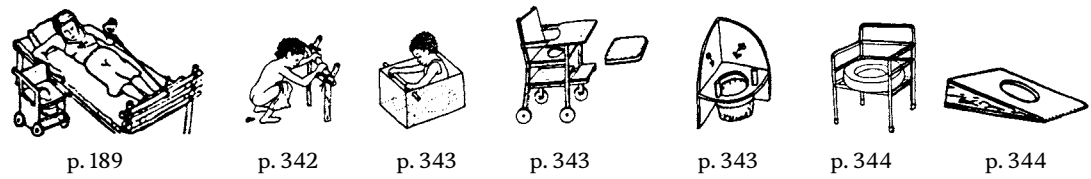

HOLDING AND REACHING AIDS (Also see pp. 6, 223, 230, 335, 336, 431, and 507.)

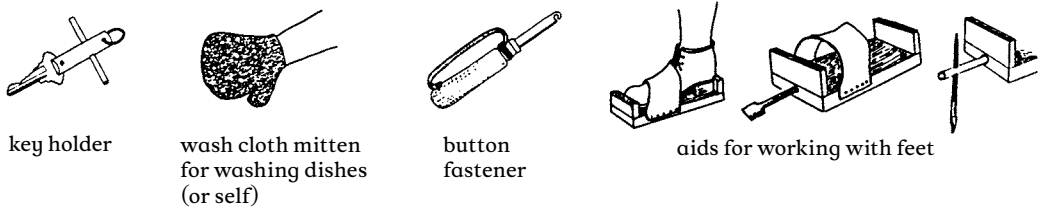

SPIRAL HOLDING AID

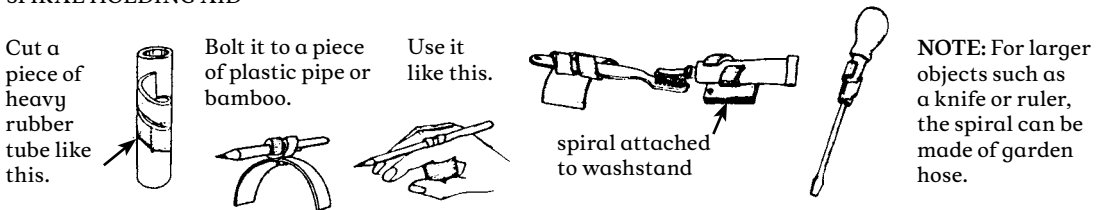

REACHING TOOL

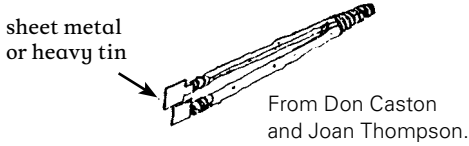

ALL-PURPOSE TOOL

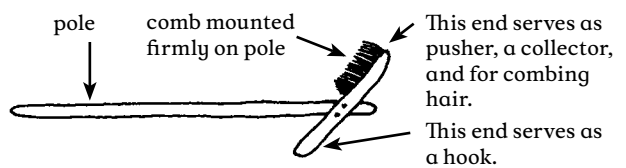

WRITING AIDS (Also see pp. 189, 223, 230, and 501.)

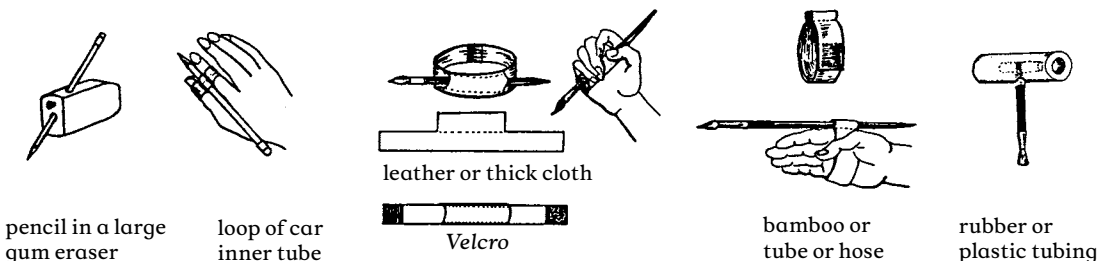

COMMUNICATION AIDS

(Also see "Loss of Vision," pp. 253 to 254 and "Hearing Loss," pp. 259 to 275.)



page turner
(p. 288 and p. 501)

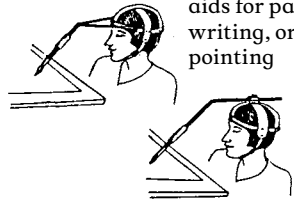

From *Art and Disabilities*

aids for painting,
writing, or
pointing

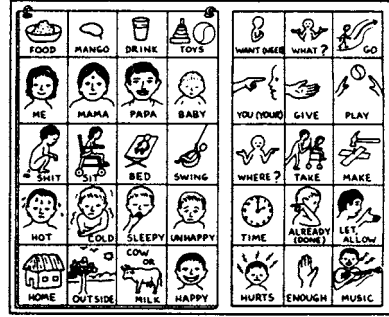

communication board

PHYSICAL EXAMINATION, MEASURING AND RECORDING AIDS

INSTRUMENT FOR LEVELING HIP

Cut 2 pieces of thin plywood like this. Fasten them together so that they slide back and forth.

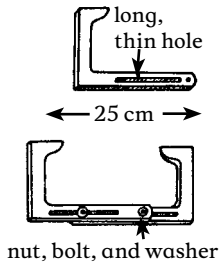

To use, close instrument around child's waist and push down against hip bones. Then raise or lower shorter leg until the instrument is level.

Cut rectangles of 1/4 inch thick boards and bolt them loosely together at one corner.

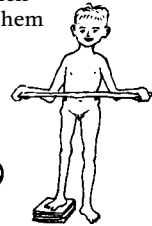
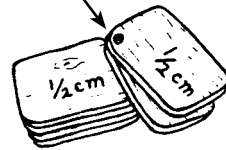

aid for measuring leg length difference (pp. 34 and 549)

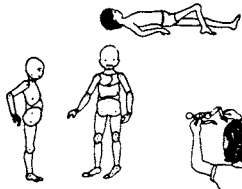

"flexikins" for measuring contractures and deformities (pp. 43 to 50)

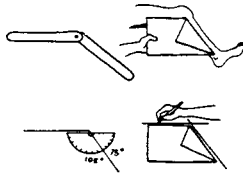

other methods for measuring contractures (pp. 43 and 79)

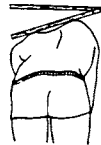

rib-hump angle measurer (p. 163)



aids for hearing examination (p. 450)

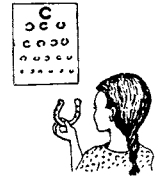

aids for seeing examination (pp. 452 and 453)

FOOT CONTRACTURE PREVENTION AIDS

Also see Chapter 59, "Correcting Joint Contractures," and Chapter 58, "Braces."



p. 81



p. 81

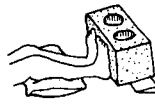

p. 81



p. 81



p. 184

EXERCISE AIDS



p. 5



p. 71

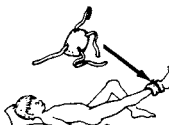

p. 141

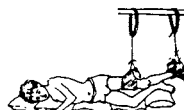

p. 145



p. 146



p. 149



p. 186



p. 229

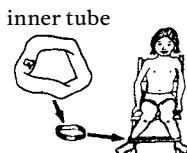

inner tube

p. 373

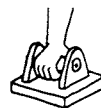

p. 388

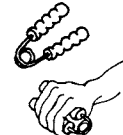

p. 392



p. 528